

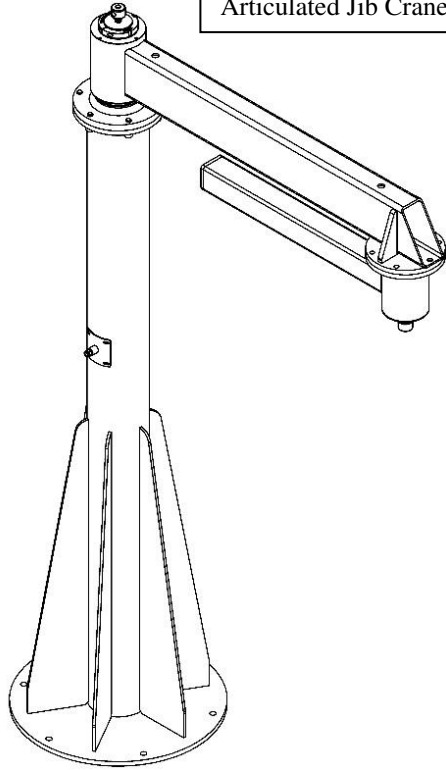

Free Standing Crane Mounting Installation Manual

Articulated Jib Crane



Articulated Lifting Arm

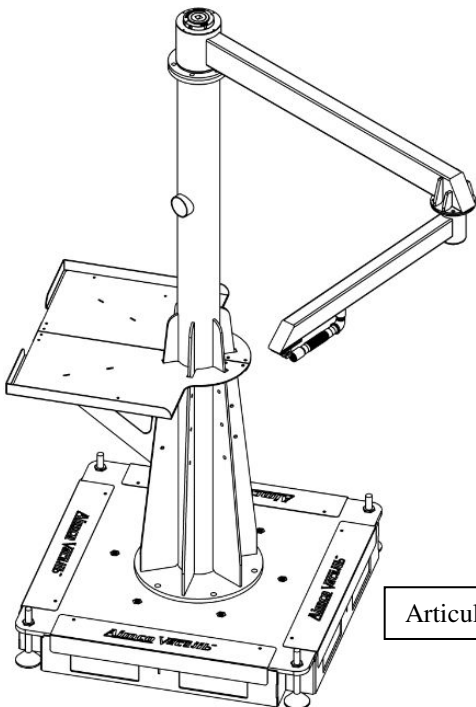
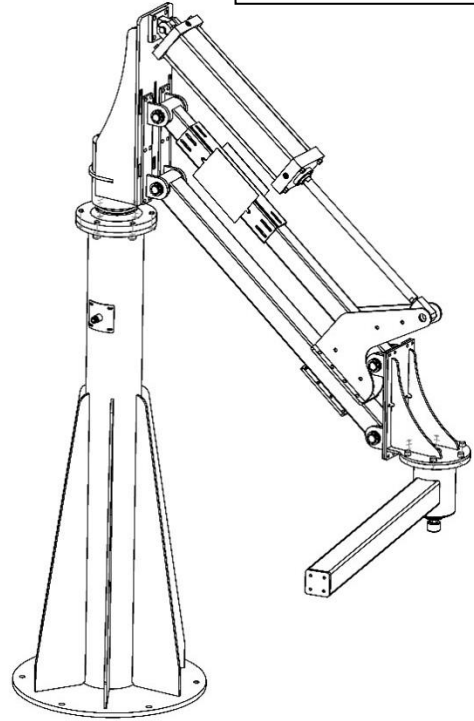

Articulated VacuJib

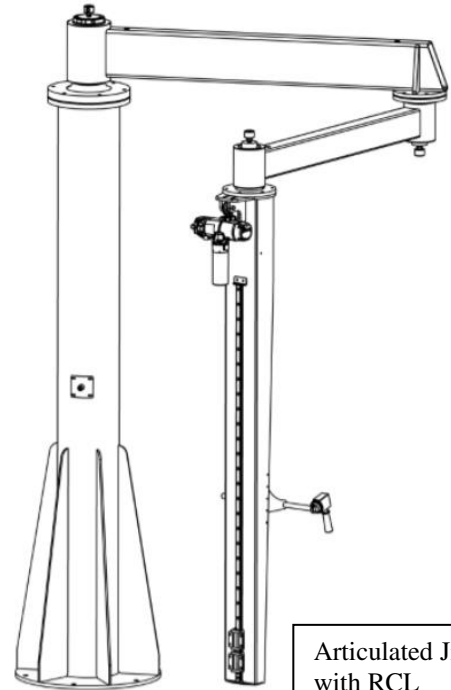

Articulated Jib Crane
with RCL



INSTALLATION



All foundation requirements assume concrete was installed per the ACI 318 Building Code Requirements for Structural Concrete. Consult a qualified structural engineer if you deviate from the recommended specifications listed below.

GENERAL INSTALLATION INSTRUCTIONS

All AIMCO lift assist equipment and associated tooling is assembled and tested at the factory.

ARTICULATED JIB CRANE REQUIREMENTS

Foundation:

For a 500lbs capacity @ 15' (7500 ft-lbs) SAJ , a 6" slab (minimum f'c> 3,500 psi) may be utilized provided it meets the following conditions.

- Slab must be a slab-on-grade supported by soil with an allowable bearing pressure greater than 1,000 pounds per square foot.
- Concrete must be in sound condition devoid of any cracks, spalling, deterioration, etc. within a 10'-0" x 10'-0" square area (jib mast centered on this area).
- Six (6) anchors on a 27" bolt circle must develop an un-factored tension greater than 3,300 pounds each. This may be obtained with a minimum 3/4" diameter Hilti HAS E-rod with a minimum 4 1/4" embedment.
- Bottom of anchor not to be within (2*(diameter+1/8")) from the bottom of the slab. 10'-0" square area must be clear of additional equipment and/or fork truck traffic.

For 865lbs capacity @ 15' (13,000 ft-lbs) HAJ, an 8" slab (minimum f'c> 3,500 psi) may be utilized provided it meets the following conditions.

- Slab must be a slab-on-grade.
- Concrete must be in sound condition devoid of any cracks, spalling, deterioration, etc. within a 10'-0" x 10'-0" square area (jib mast centered on this area).
- Six (6) anchors on a 27" bolt circle must develop an un-factored tension greater than 4,700 pounds each. This may be obtained with a minimum 3/4" diameter Hilti HAS E-rod with a minimum 5" embedment.
- Bottom of anchor not to be within (2*(diameter+1/8")) from the bottom of the slab. 10'-0" square area must be clear of additional equipment and/or fork truck traffic.

Note: If neither of the two above conditions can be met, or if a factor of safety above 3 to 1 is desired then a dedicated jib foundation (5ft x 5ft x 4ft deep) must be poured.

Temperature Limits:

- Your articulated jib crane should be installed where it is not subject to radical changes in temperature or temperatures outside of the limits listed below. Temperatures outside of the recommended limits may cause problems with bearings, pneumatic systems, moving parts and tooling.
- Unless otherwise specified, AIMCO equipment is designed for indoor use only.
Minimum Temperature -40 degrees Fahrenheit
Maximum Temperature +140 degrees Fahrenheit

Air Supply:

- Clean, dry air (90 PSI minimum). It is recommended that a filter regulator be placed between the incoming plant air and the manipulator.



INSTALLATION Pedestal



Pedestal must be level to prevent the articulated jib arms from drifting.

- A.) Mount the pedestal on a level, appropriately sized concrete foundation.
- B.) The pedestal must be leveled prior to securing to the floor. Level across the top mounting plate (See Fig-3).
- C.) Shim stock beneath the pedestal mounting plate may be used to aid leveling the pedestal (See Fig-3).
- D.) Position the pedestal on the foundation with the supply air intake cover positioned to minimize piping.
- E.) **Recommendation only!** Use 3/4" Concrete Anchors (provided by others) to mount the pedestal. Consult structural engineer for concrete anchor recommendations.

AIMCO Pedestal mounting for:
SAJ & HAJ Series

FIG-1

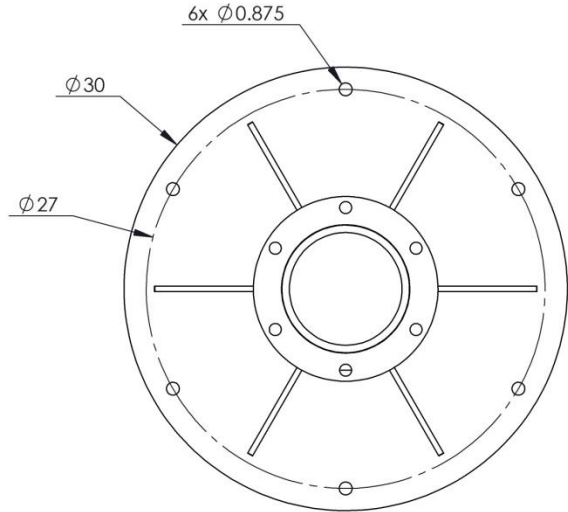

AIMCO Pedestal mounting for:
BAJ & VAJ Series

FIG-2

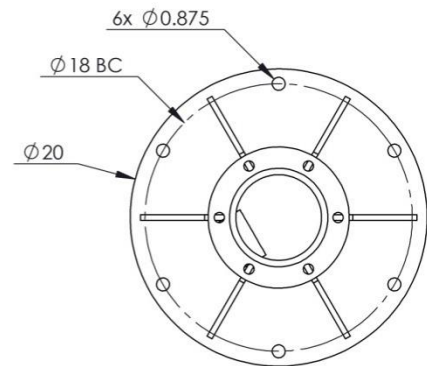
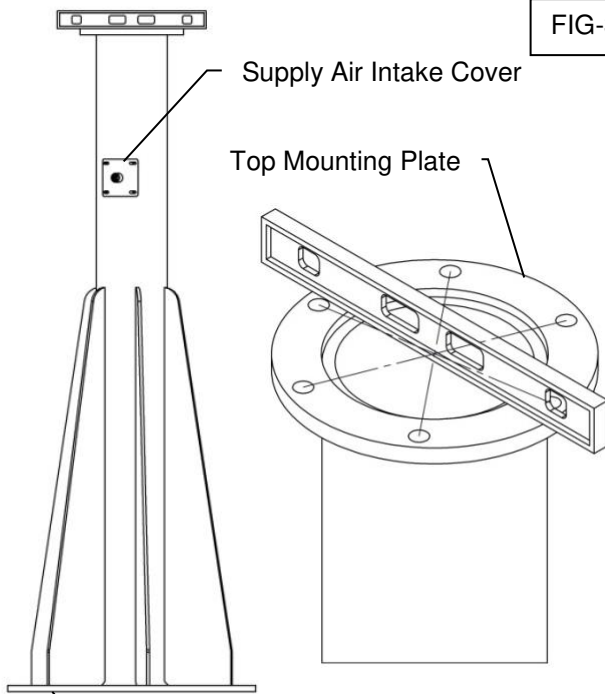

FIG-3



Shim under Pedestal Mounting Plate.
If shim(s) exceed 1/8" thickness, fill
gaps with high strength grout.



INSTALLATION Articulated Jib

- A.) Assure the 1/2" push to connect fitting is securely connected to the bottom of the primary bearing housing.
- B.) Fold back the secondary arm beneath the primary arm (as shown in Fig-4). Tie the two arms together to prevent them from unfolding during lifting. Using a forklift, spread the forks and place them between the primary and secondary arm so that the load is lifted from the bottom side of the primary arm. Secure the arms to the forks with "C" clamps prior to lifting overhead.
- C.) Route the 1/2" airline down through the pedestal and out of the hole located on the side of the pedestal (See Fig-4).
- D.) Slowly lower the arms onto the top of the pedestal, aligning the bolt holes. Secure the arms to the pedestal with 6 bolts from the accessory box. (Bolts will vary between series of articulated jibs) Torque bolts using the chart shown in Fig. 4. **NOTE:** It is recommended that LocTite threadlocker be used for this connection.
- E.) Connect the 1/2" airline to the 1/2" push to connect fitting and secure the 1/2" NPT female fitting plate to the pedestal using the 1/4-20 SHCS provided.
- F.) **System Power:** Clean, dry air (90 PSI minimum). It is recommended that a filter regulator be placed between the incoming plant air and the manipulator.
- G.) Carefully rotate the jib crane to ensure clearance between jib arms and the surrounding areas.
- H.) If stud anchors are used at the Pedestal Base, cut-off excess thread above the nut so that 2-3 threads are exposed above the nut; 6 places.

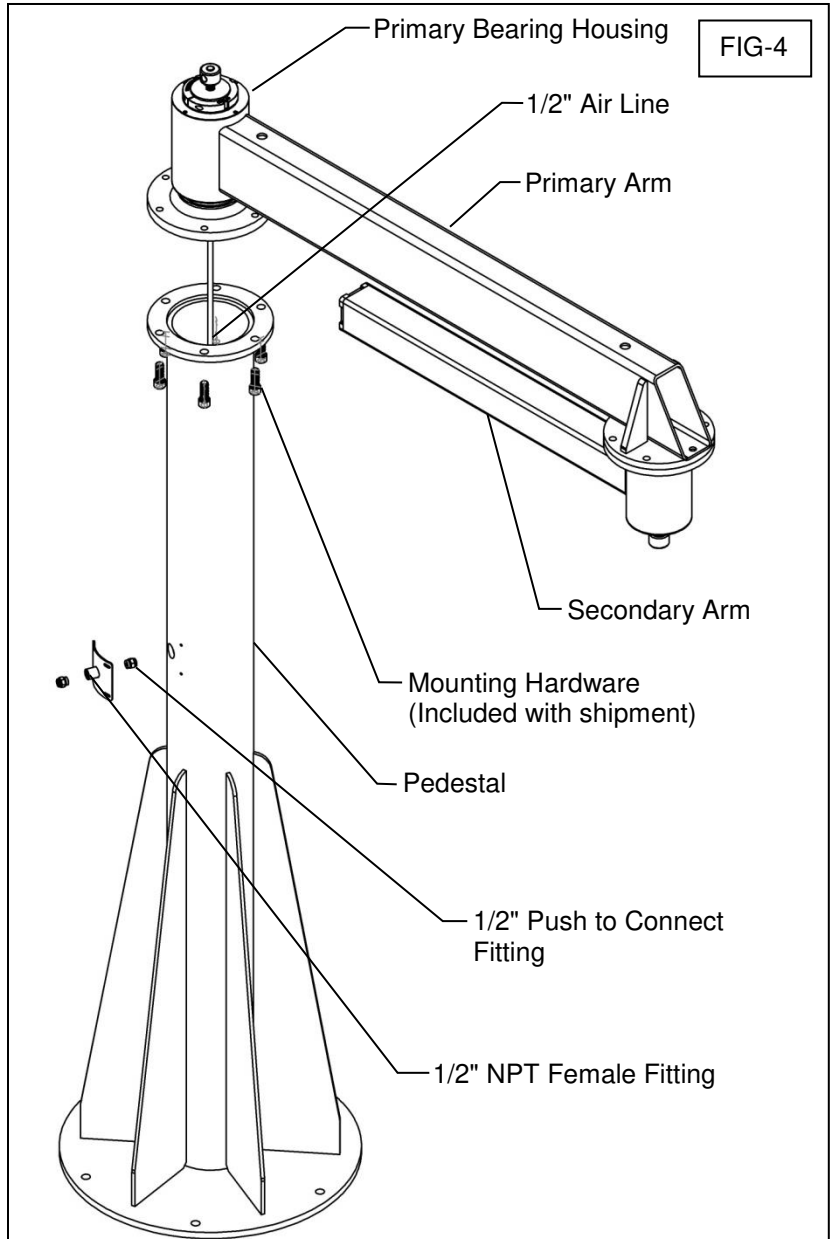

Do Not Over tighten Bolts: Over tightening will result in higher pull forces.

SHCS Bolt Size	Torque Ft.-Lbs.
1/2-13	110
5/8-11	210
3/4-10	380

INSTALLATION Articulated Jib with Rigid Column Lift (RCL)

- A.) Assure the 1/2" push to connect fitting is securely connected to the bottom of the primary bearing housing.
- B.) Fold back the secondary arm beneath the primary arm (as shown in Fig-5). Tie the two arms together to prevent them from unfolding during lifting. Using a forklift, spread the forks and place them between the primary and secondary arm so that the load is lifted from the bottom side of the primary arm. Secure the arms to the forks with "C" clamps prior to lifting overhead.
- C.) Route the 1/2" airline down through the pedestal and out of the hole located on the side of the pedestal (See Fig-5).
- D.) Slowly lower the arms onto the top of the pedestal, aligning the bolt holes. Secure the arms to the pedestal with 6 bolts from the accessory box. (Bolts will vary between series of articulated jibs) Torque bolts using the chart shown in Fig-5. **NOTE:** It is recommended that LocTite threadlocker be used for this connection.
- E.) Connect the 1/2" airline to the 1/2" push to connect fitting and secure the 1/2" NPT female fitting plate to the pedestal using the 1/4-20 SHCS provided.
- F.) **System Power:** Clean, dry air (90 PSI minimum). It is recommended that a filter regulator be placed between the incoming plant air and the manipulator.
- G.) Carefully rotate the jib crane to ensure clearance between jib arms and the surrounding areas.
- H.) If stud anchors are used at the Pedestal Base, cut-off excess thread above the nut so that 2-3 threads are exposed above the nut; 6 places.
- I.) Attach the RCL to the secondary bearing plate with the hardware provided.

FIG-5

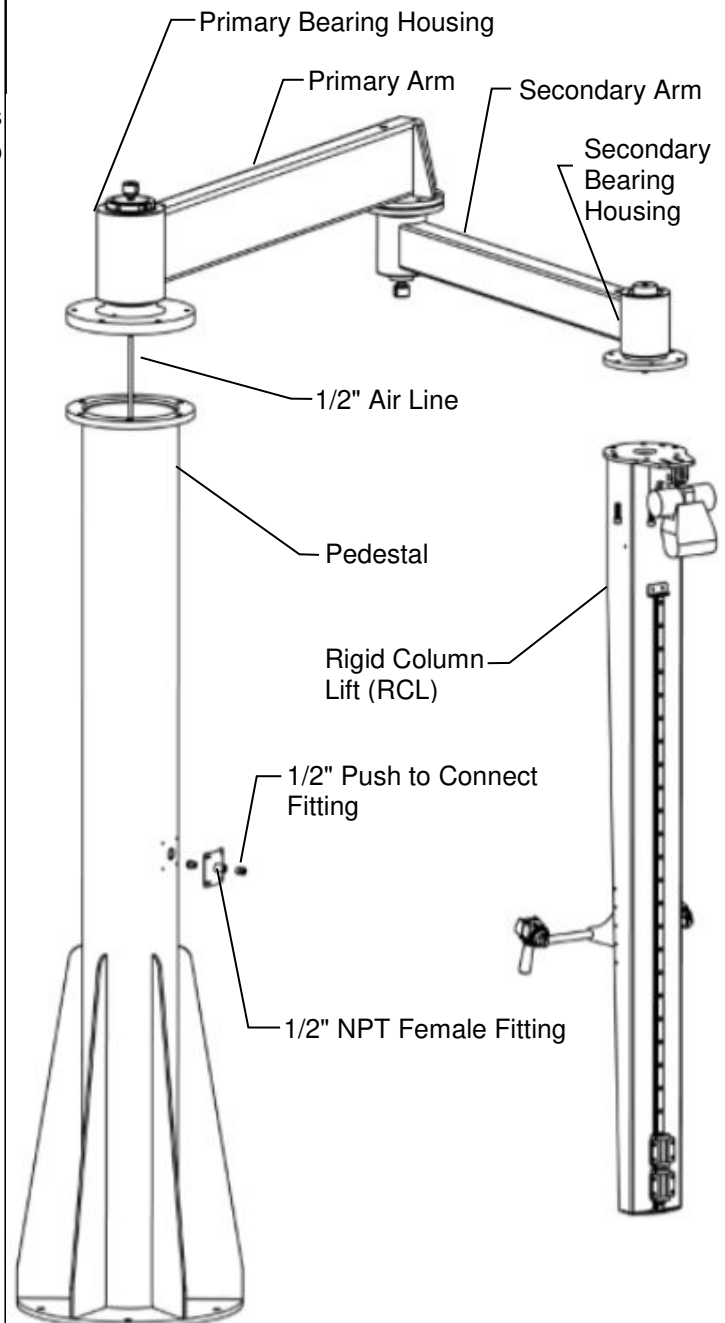

SHCS Bolt Size	Torque Ft.-Lbs.
1/2-13	110
5/8-11	210
3/4-10	380



Do Not Over tighten Bolts: Over tightening will result in higher pull forces.



INSTALLATION Articulated Lifting Arm

- A.) Assure the 1/2" push to connect fitting is securely connected to the bottom of the primary bearing housing.
- B.) Align the primary bearing housing with the pedestal (as shown in Fig-6).
- C.) Route the 1/2" airline down through the pedestal and out of the hole located on the side of the pedestal (See Fig-6).
- D.) Slowly lower the arm onto the top of the pedestal, aligning the bolt holes. Secure the arms to the pedestal with 6 bolts from the accessory box. Torque bolts using the chart shown in Fig-6. **NOTE:** It is recommended that Loctite threadlocker be used for this connection.
- E.) Align the secondary jib arm with the primary arm and attach with the mounting hardware included. **NOTE:** It is recommended that Loctite threadlocker be used for this connection.
- F.) Connect the 1/2" airline to the 1/2" push to connect fitting and secure the 1/2" NPT female fitting plate to the pedestal using the 1/4-20 SHCS provided.
- G.) **System Power:** Clean, dry air (90 PSI minimum). It is recommended that a filter regulator be placed between the incoming plant air and the manipulator.
- H.) Carefully rotate the jib crane to ensure clearance between jib arms and the surrounding areas.
- I.) If stud anchors are used at the Pedestal Base, cut-off excess thread above the nut so that 2-3 threads are exposed above the nut; 6 places.

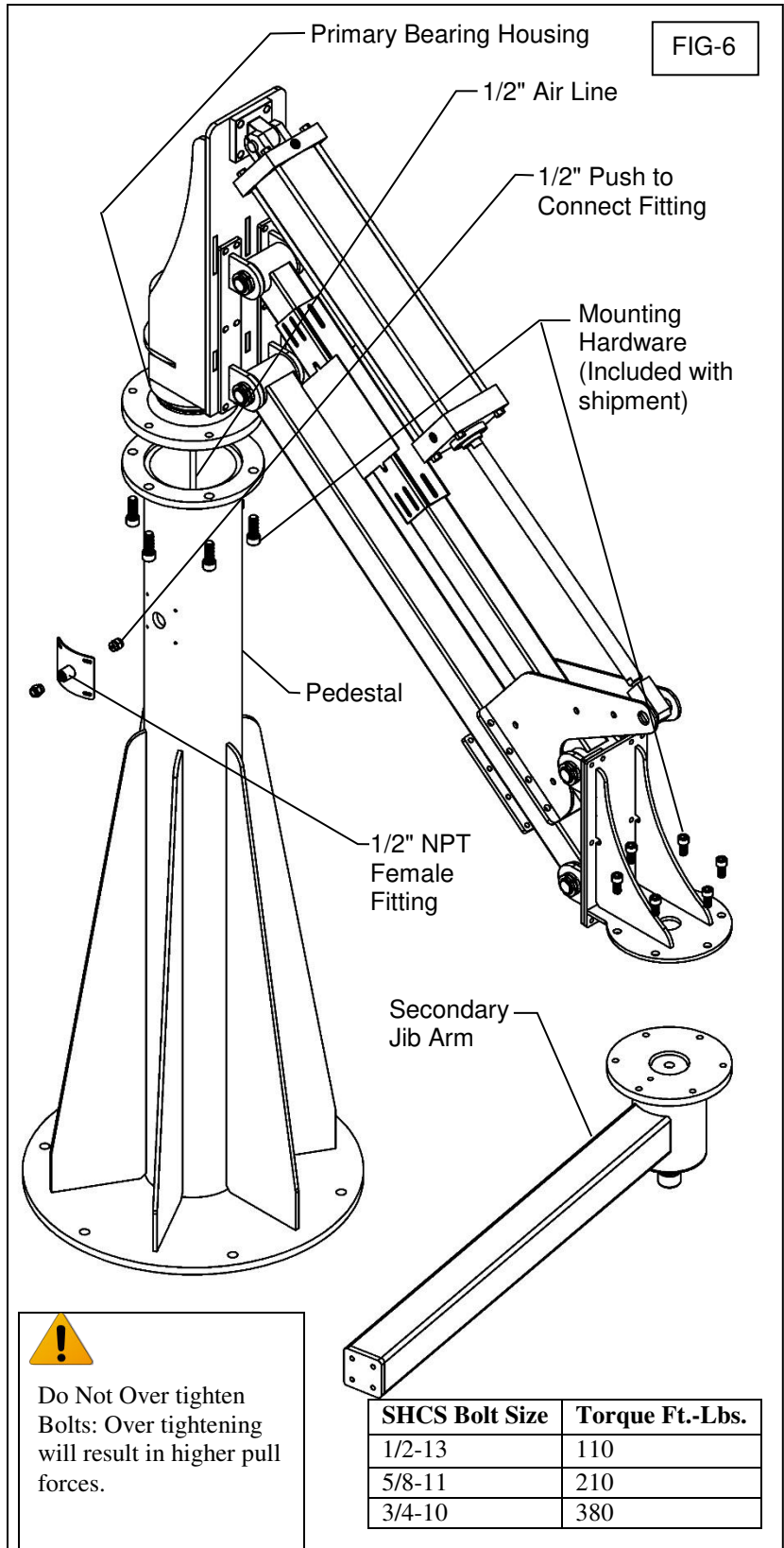



INSTALLATION Articulating VacuJib

- A.) If a portable base was purchased then attach the pedestal as shown in Fig-7. Refer to the pedestal mounting page if not using a portable base.
- B.) Assure the vacuum tube, either 1" ID or 2" ID, is securely connected to the bottom of the primary bearing housing.
- C.) Fold back the secondary arm beneath the primary arm (as shown in Fig-7). Tie the two arms together to prevent them from unfolding during lifting. Using a forklift, spread the forks and place them between the primary and secondary arm so that the load is lifted from the bottom side of the primary arm. Secure the arms to the forks with "C" clamps prior to lifting overhead.
- D.) Align the primary bearing housing with the pedestal (as shown in Fig-6). Route the Vacuum Tube down through the pedestal and out of the hole located on the side of the pedestal (See Fig-7).
- E.) Slowly lower the arm onto the top of the pedestal, aligning the bolt holes. Secure the arms to the pedestal with 6 bolts and 6 nuts from the accessory box. Torque bolts using the chart shown in Fig-7. **NOTE:** It is recommended that LocTite threadlocker be used for this connection.
- F.) Connect the vacuum tube to the vacuum pump (not shown).
- G.) **System Power:** 240V or 480V 3 Phase.
- H.) Carefully rotate the jib crane to ensure clearance between jib arms and the surrounding areas.

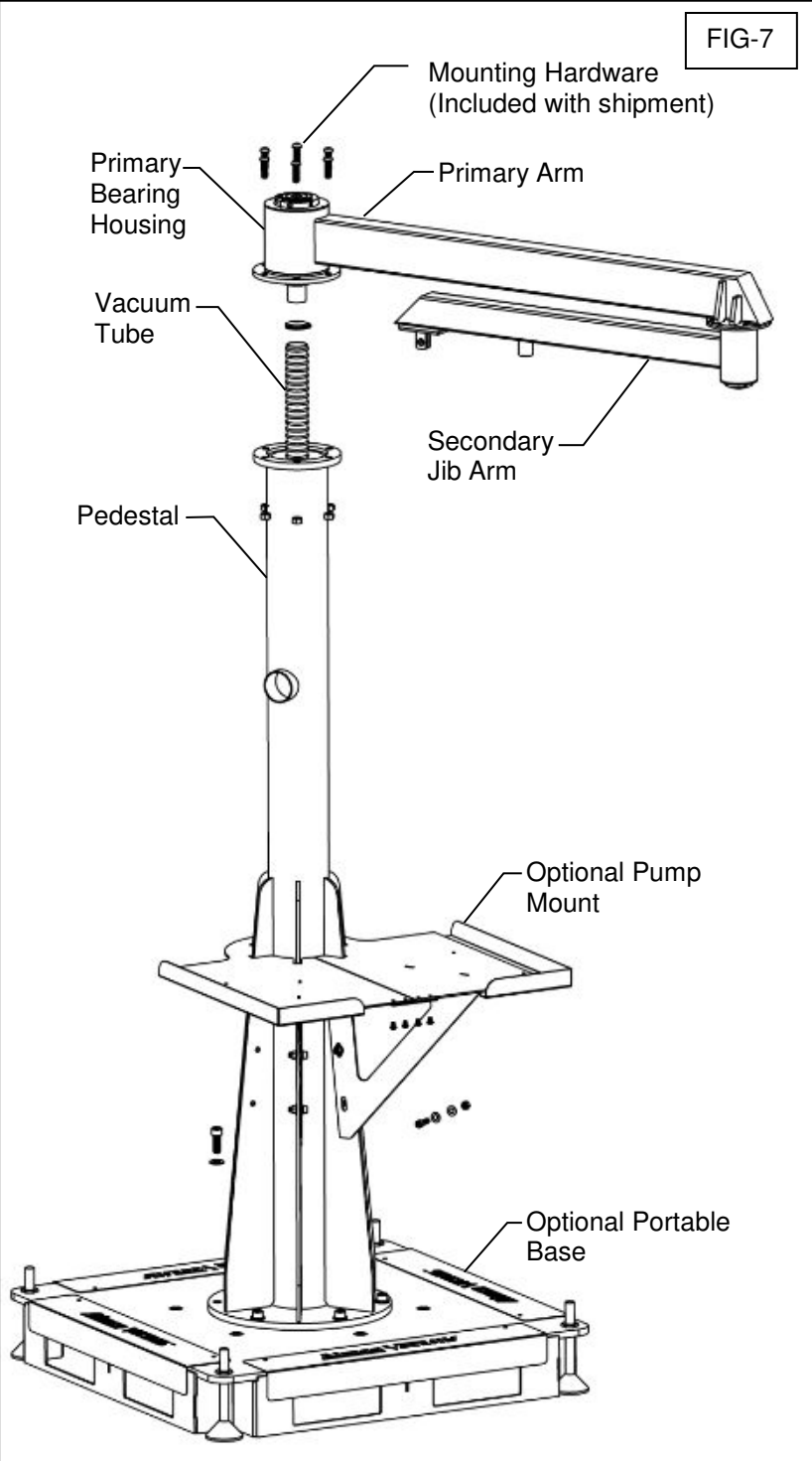

Do Not Over tighten Bolts: Over tightening will result in higher pull forces.

SHCS Bolt Size	Torque Ft.-Lbs.
1/2-13	110
5/8-11	210
3/4-10	380



INSTALLATION Articulated Jib Bearing Adjustment

Clamp Nut Assembly Instructions:

With the cap screw loose, assemble the clampnut onto the shaft threads until the clampnut threads are fully engaged. Then hand tighten the cap screw while rotating the clampnut back and forth until a light drag is felt. This is essential to eliminate the pitch diameter differential between the threads. Failure to snug the cap screw could result in the opening of the clampnut threads during preloading and subsequent loss of holding power. It also pulls the clampnut central on the threads.

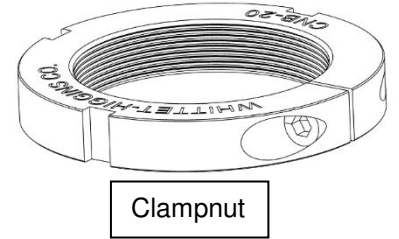

Warning: Never use an impact wrench or other automated device to initially start the clampnut onto the shaft threads as it may cause cross-threading due to the inherent flexibility of the split design. The lightly snugged clampnut is now ready to be rotated into position against the bearing/components, preload applied, and cap screw tightened to the recommended torque. Do not over-torque the cap screws as the clampnut may close up completely with a possible loss of holding power.

Clampnut screw recommended Torque Values:

Low Head Metric Screw Size	Torque Inch-Lbs.
M4	24
M6	70
M8	150
M10	300
M12	510

AIMCO's Articulated Jib Cranes have two 360-degree rotation bearing assemblies. The primary and secondary rotation bearings. Each of these rotation bearing assemblies have some adjustment, which increases or decreases the compression placed on the bearings in the assembly. By adjusting compression, the arm rotation becomes easier or tighter.

Tools Required:

1. Metric Allen Wrenches
2. Spanner Wrench
3. Hammer

- A.) Loosen the Allen Head lockscrew see Fig-8 and Clampnut instructions above. Do Not Remove the Lockscrew.
- B.) Place the spanner wrench on the outside diameter of the nut. Position the wrench so that it does not lie across the allen head screw area.
- C. Use a hammer to either tighten or loosen the compression nut. A one-eighth to one-quarter turn will make a difference. Do Not Loosen Completely; Compression on the bearings must be retained. Re-tighten the allen head screw in the split nut.

FIG-8

