

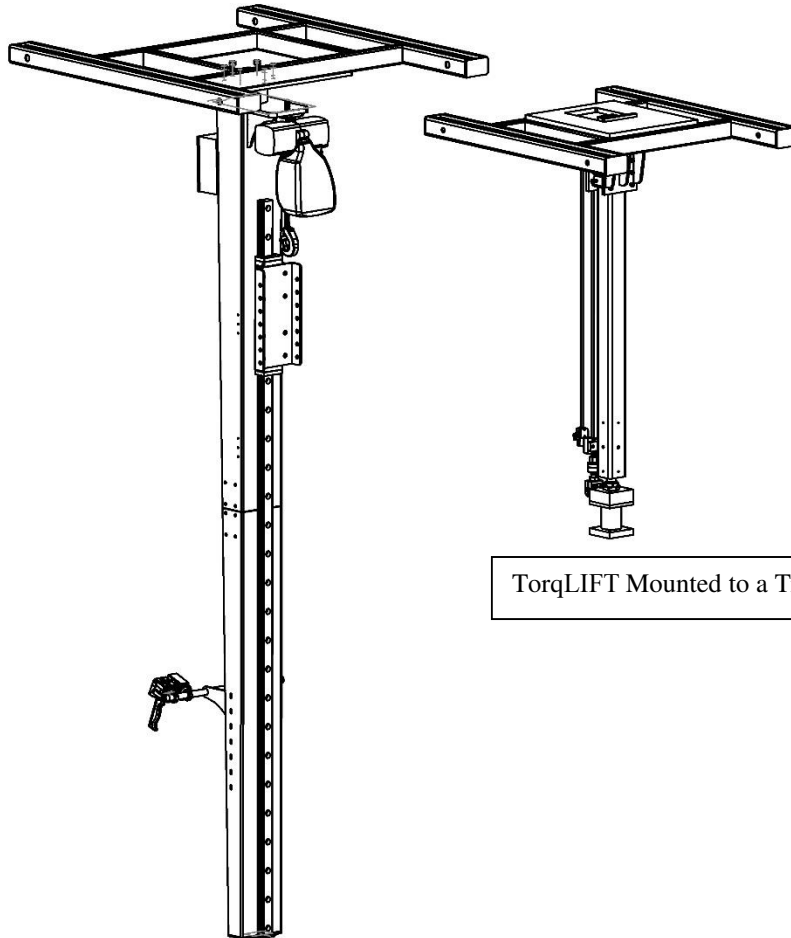

Aimco Manufacturing
203 Matzinger Road
Toledo, OH 43612

Overhead Bridge Crane Integration Manual

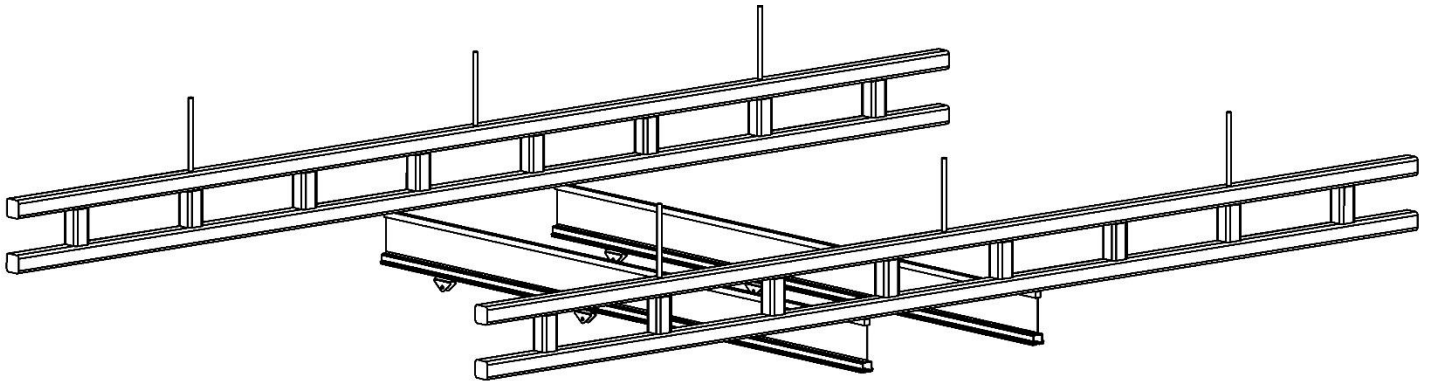

StackerLIFT Mounted to a Trolley Platform

TorqLIFT Mounted to a Trolley Platform



INSTALLATION Trolley Platform to a Dual Bridge Crane

Note: Refer to the crane manufactures installation manual for all bridge crane safety precautions and warnings.

- A.) Ensure that the molded bumper is in place. See Fig1 for end stop installation.
- B.) Install the AIMCO trolley platform to the trollies using the supplied hardware.
- C.) Ensure that any electric or pneumatic festooning cannot be snagged or pinched.

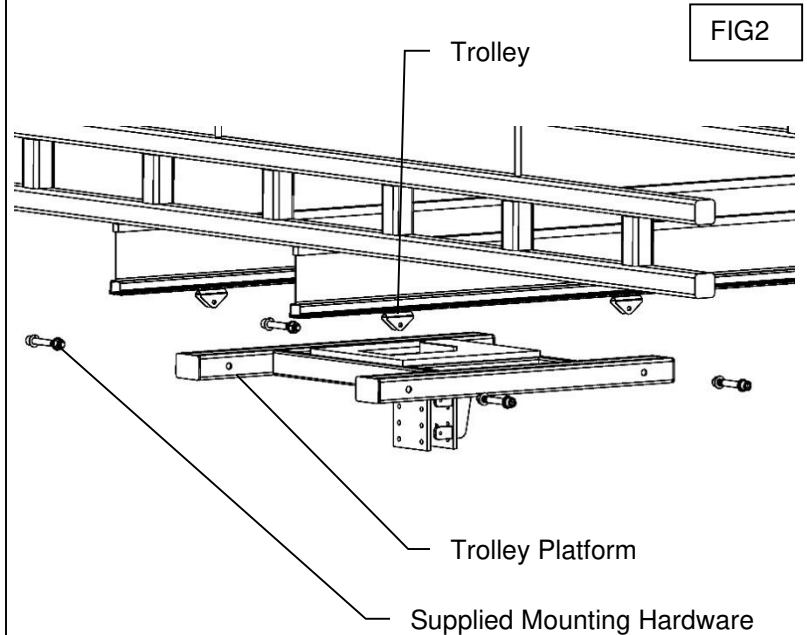
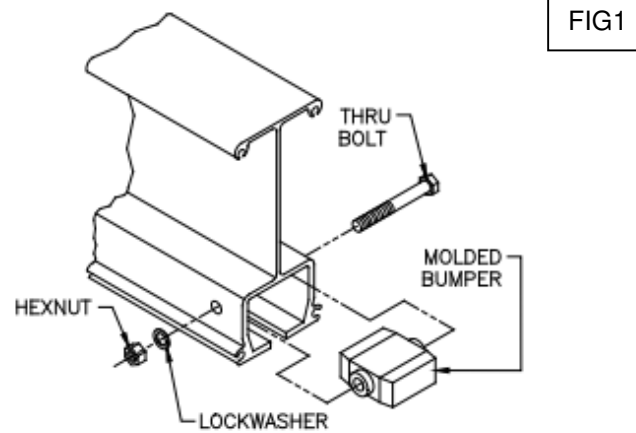

SHCS Bolt Size	Torque Ft.-Lbs.
1/2-13	110
5/8-11	210
3/4-10	380



Do Not Over tighten Bolts: Over tightening will result in higher pull forces.



INSTALLATION StackerLIFT with Trolley Platform

- D.) Assure the 1/2" push to connect fitting is securely connected to the top of the primary bearing housing.
- E.) Align the primary bearing housing with the trolley platform (as shown in Fig-6).
- F.) Route the 1/2" airline up through the trolley platform for connection to the main air supply. (See Fig-6).
- G.) Align the bolt holes and secure the StackerLIFT to the trolley platform with 6 bolts from the accessory box. Torque bolts using the chart shown in Fig. 6.
NOTE: It is recommended that LocTite threadlocker be used for this connection.
- H) If assembling a StackerLIFT with an articulated jib, please see Fig. 4 for detailed instructions.

System Power: Clean, dry air (90 PSI minimum). It is recommended that a filter regulator be placed between the incoming plant air and the manipulator.

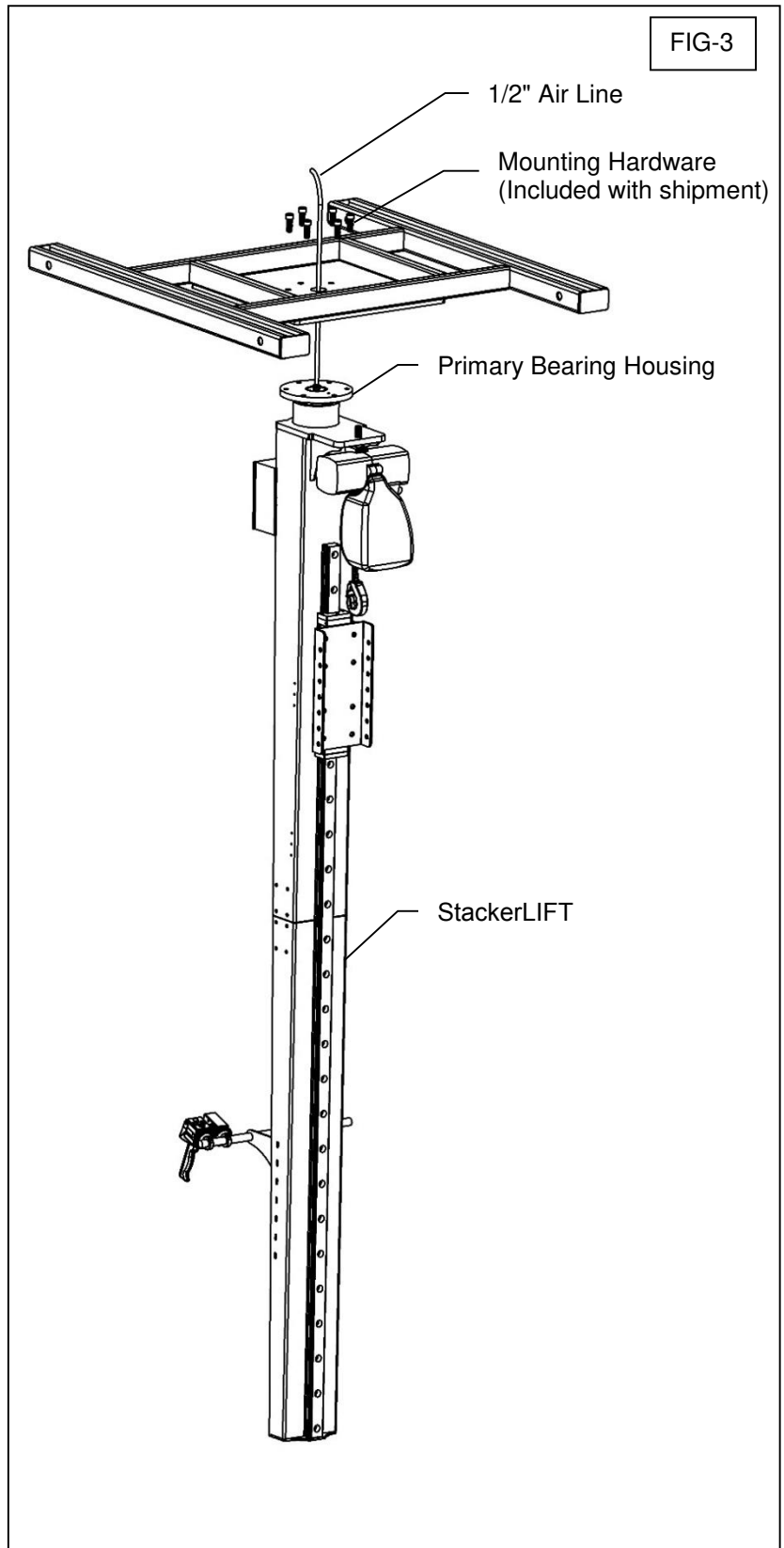

INSTALLATION TorqLIFT with Trolley Platform

- I.) Attach the TorqLIFT Platform to the four Trolleys on a dual bridge crane (Trolleys and crane to be supplied by other).
- J.) Align the TorqLIFT Tube with the Trolley Platform.
- K.) Position the Cylinder Mounting Plate above the Compression Plate (shown in Assembled View) and mount Compression Plate to Trolley Platform.
- L.) Align the TorqLIFT upright & perpendicular to the Trolley Platform by using the Vertical Alignment Plate Hardware.
- M.) Note: The Wrist Swivel is to be limited to 359° of rotation to avoid a disconnection in the air line.
- N.) Connect (plumb) airlines to up/down pendant. Match the labeled air line with its mating fitting (air lines and pendant are not shown).
- O.) Note: TorqLIFT Tube can be mounted through the Trolley Platform to gain vertical clearance if necessary.

