

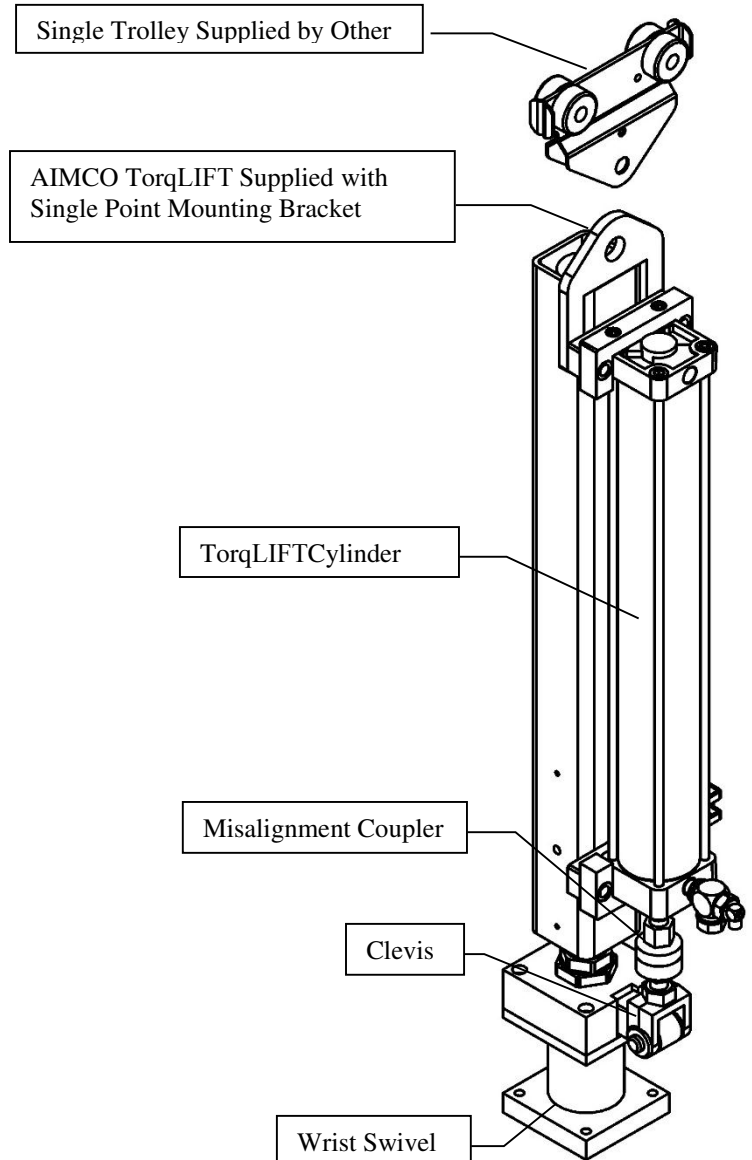

# TorqLIFT Installation Guide

## Single Point

- A.) Align the TorqLIFT with the trolley and secure using the Trolley Pin. Trolley and mounting pin to be supplied by other.
- B.) Note: The Wrist Swivel is to be limited to 359° of rotation to avoid a disconnection in the air line.
- C.) Connect (plumb) airlines to up/down pendant. Match the labeled air line with its mating fitting (air lines and pendant are not shown).



# TorqLIFT Installation Guide

## Jib Mount

- A.) Align the TorqLIFT Tube with the end of the Secondary Jib Arm.
- B.) Position the Cylinder Mounting Plate above the Compression Plate (shown in Assembled View).
- C.) Mount Compression Plate to Secondary Jib Arm with the Vertical Alignment Plates positioned as shown.
- D.) Align the TorqLIFT upright & perpendicular to the Jib Arm by using the Vertical Alignment Plate Hardware.
- E.) Note: The Wrist Swivel is to be limited to 359° of rotation to avoid a disconnection in the air line.
- F.) Connect (plumb) airlines to up/down pendant. Match the labeled air line with its mating fitting (air lines and pendant are not shown).

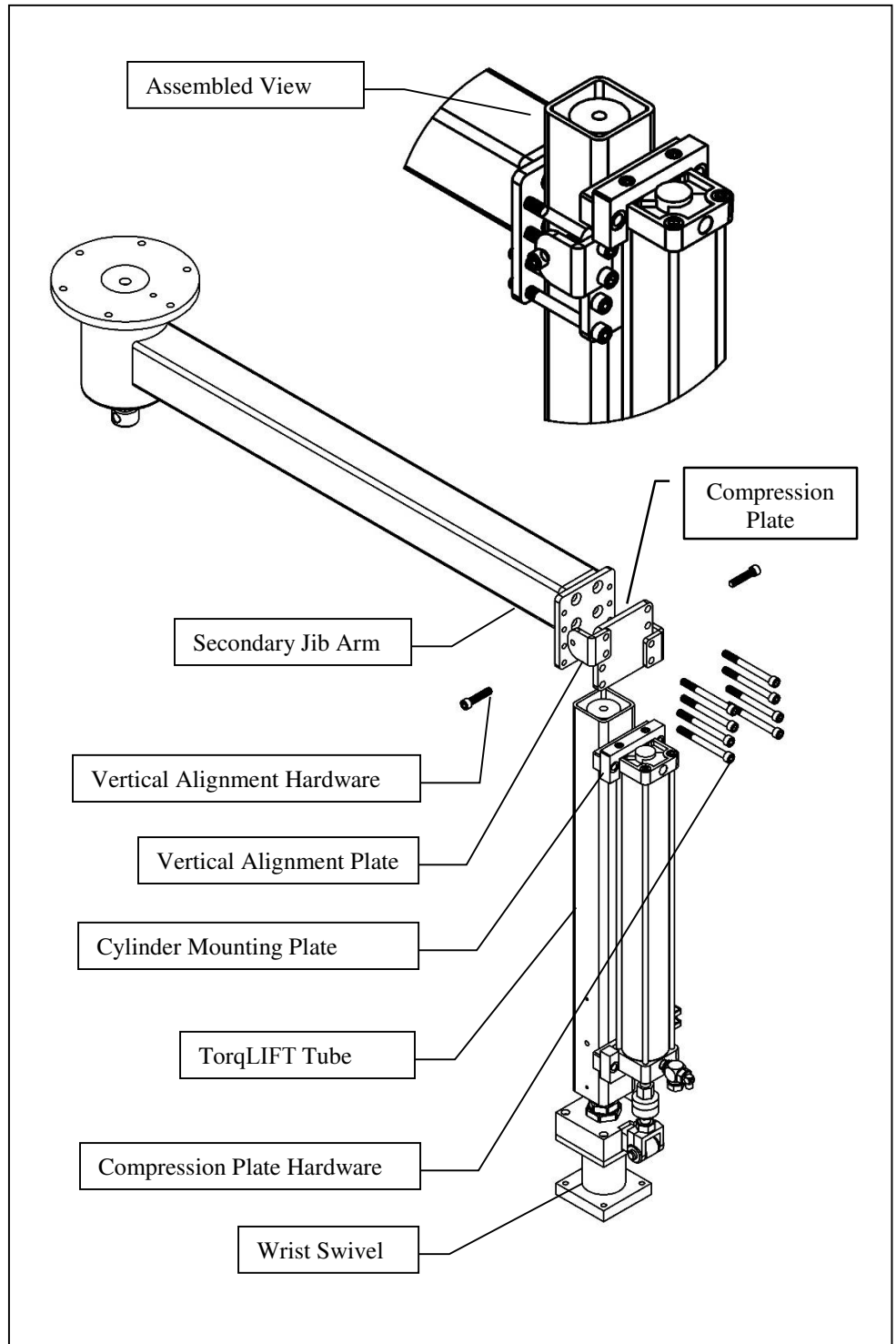

# TorqLIFT Installation Guide

## Trolley Platform Mount

- A.) Attach the TorqLIFT Platform to the four Trolleys on a dual bridge crane (Trolleys and crane to be supplied by other).
- B.) Align the TorqLIFT Tube with the Trolley Platform.
- C.) Position the Cylinder Mounting Plate above the Compression Plate (shown in Assembled View) and mount Compression Plate to Trolley Platform.
- D.) Align the TorqLIFT upright & perpendicular to the Trolley Platform by using the Vertical Alignment Plate Hardware.
- E.) Note: The Wrist Swivel is to be limited to 359° of rotation to avoid a disconnection in the air line.
- F.) Connect (plumb) airlines to up/down pendant. Match the labeled air line with its mating fitting (air lines and pendant are not shown).
- G.) Note: TorqLIFT Tube can be mounted through the Trolley Platform to gain vertical clearance if necessary.

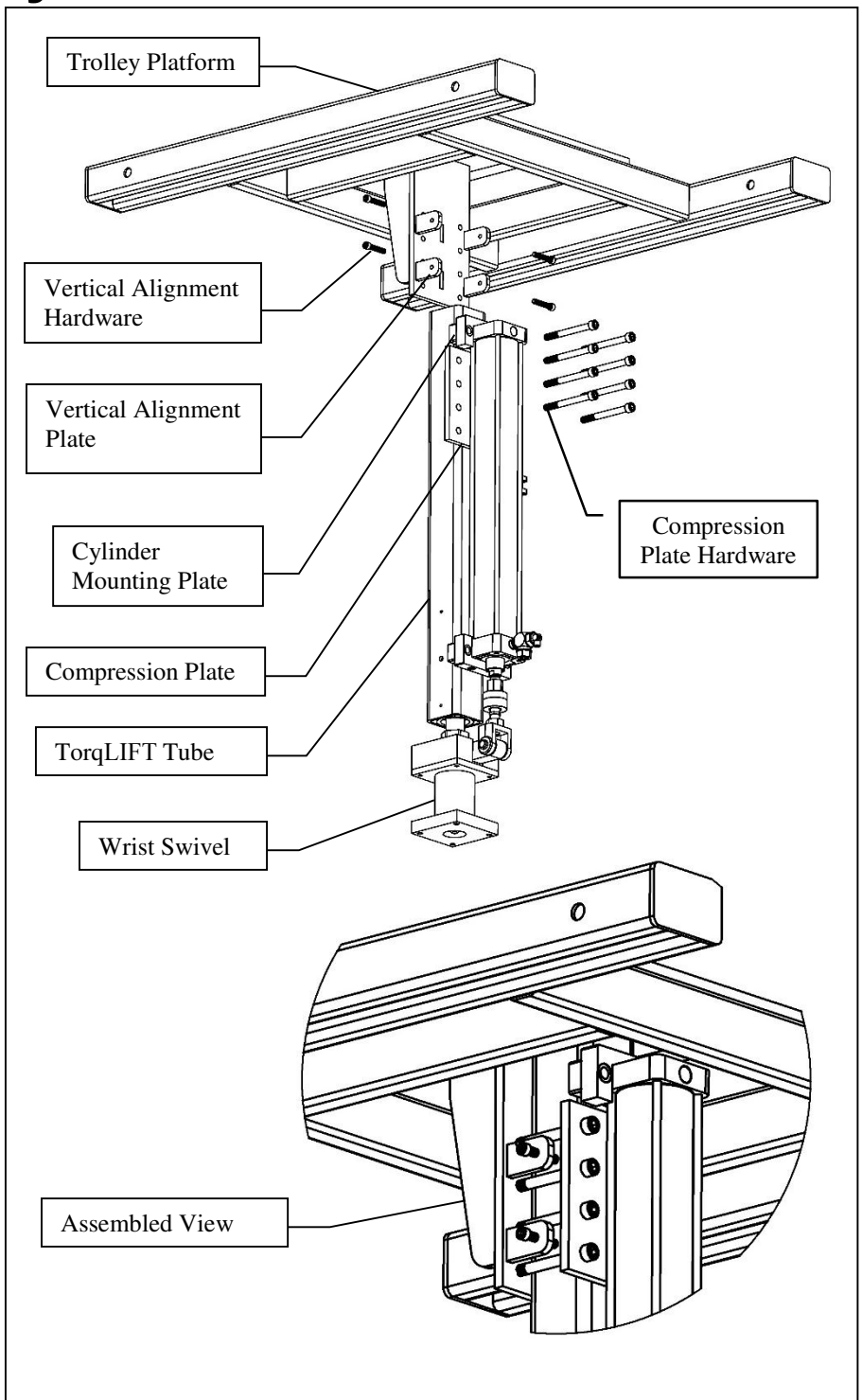

## TorqLIFT Guide Shaft Adjustment

Guide shaft adjustment instructions to be used to ensure the guide shaft travels smoothly inside of the linear bearings.

- A.) Check to see if the Guide Shaft Stop Plate is centered with the square tube.
- B.) If the shaft is not plumb with the square tubing of the TorqLIFT then loosen the three Shoulder Bolts (**DO NOT REMOVE SHOULDER BOLTS**).
- C.) Adjust the Set Screws to center the internal bearing sleeve. After ensuring the Guide Shaft is plumb, tighten the three Shoulder Bolts and all six Set Screws.
- D.) Using the UP/Down Pendant, run the TorqLIFT up and down to ensure the shaft is traveling smoothly within the linear bearings. Check for any chatter marks on the shaft and check the Stop Plate to make sure that it remains centered with the square tube during vertical travel.

