

# LoProfile™

LX SERIES LO-PROFILE LIFT TABLES

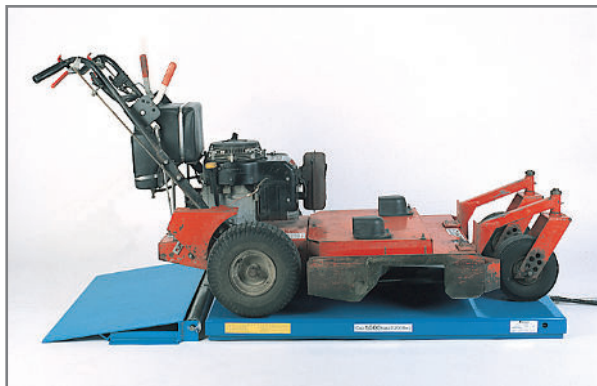

The Bishamon LX-Series Lo-Profile™ are rugged electrohydraulic lift tables. They are designed for capacities of 550 lbs. to 4,400 lbs. and are available in a variety of platform sizes and lift heights.

LoProfile™ lift tables provide lifting power from a very low elevation. This low collapsed height provides easy access for pallet jacks, 4 - wheeled carts and other devices requiring low profile. The LoProfile™ is also an excellent choice for conveyor transfer.

LoProfile™ lift tables help increase productivity and reduce worker strain by positioning materials at a convenient operating height for worker efficiency.

LoProfile™ lift tables are widely used in production facilities, assembly areas, shipping and warehousing facilities. With great emphasis being placed on ergonomics and the reduction of repetitive motions, the LX Series meets the ever-growing need for work positioning assistance in manufacturing operations.

All Bishamon products are designed and constructed for positioning applications under the toughest working conditions, offering years of trouble-free operation. They reflect over 55 years of proven Bishamon performance.

## Bishamon

Bishamon Industries Corporation

5651 East Francis Street  
Ontario, California 91761-3601

(909) 390-0055 • (800) 358-8833  
Fax (909) 390-0060

[www.bishamon.com](http://www.bishamon.com)

**Warranty** - Bishamon Industries Corp. ("Bishamon") warrants its products to be free from defects in material and workmanship for a period of one (1) year from the date of initial shipment. This warranty shall not apply to any misuse, mishandling, accident, shipping, alteration, or unauthorized repair of any Bishamon product or part. For complete details of warranty, please contact Bishamon at 800-358-8833.



# LoProfile™

## LX SERIES LO-PROFILE LIFT TABLES

Working Harder To  
Make Your Life Easier

### LoProfile LX Series

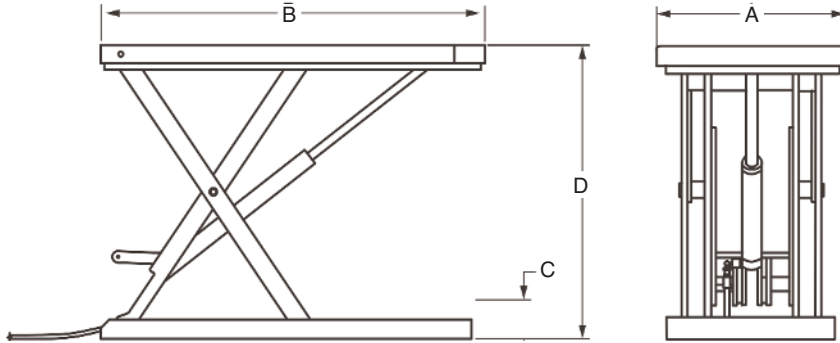

Selector Table for LX Series Lift Tables

Model	Capacity (lbs.)	Table (in.) W x L (A) (B)	Table Height (in.)		Power Units (see notes)	Approx Time Loaded (sec.)		Ship Weight (lbs.)
			Min. (C)	Max. (D)		Up	Down	
LX-25S	550	23.5 x 32.5	2.9	20.9	1/2 HP / 115V	7	5	213
LX-25L	550	23.5 x 40.0	2.9	30.0	1/2 HP / 115V	10	8	257
LX-50S	1,100	23.5 x 32.5	2.9	20.9	1/2 HP / 115V	13	8	228
LX-50L	1,100	23.5 x 40.0	2.9	30.0	1/2 HP / 115V	20	10	277
LX-100W	2,200	34.5 x 51.0	3.3	38.6	E / 1 / 3 / 3-480*	11	15	606
LX-100N	2,200	24.0 x 51.0	3.3	38.6	E / 1 / 3 / 3-480*	11	14	490
LX-200WM	4,400	45.5 x 61.5	4.3	39.4	E / 1 / 3 / 3-480*	23	36	1,100
LX-200N	4,400	33.5 x 55.5	4.3	39.4	E / 1 / 3 / 3-480*	23	36	860
LX-200WL	4,400	45.5 x 81.0	4.3	39.4	E / 1 / 3 / 3-480*	23	36	1,238

\* E = 1 HP / 115V (115V motors increase up time up to 50%)

\*1 = 1 HP / 230V / 1 PHASE

\*3 = 1 HP / 230V / 3 PHASE

\*3-480 = 1 HP / 480V / 3 PHASE

### Standard Features

- Extremely low collapsed heights of 2.9" to 4.3" provides access for rolling products, carts or pallet trucks
- Electric full-perimeter toeguard around the platform provides optimum operator safety
- Heavy-duty construction with captured scissor rollers for maximum stability
- Remote power unit with hand held control
- 24V operator control voltage
- High performance external electric-hydraulic power unit
- Durable steel braided hydraulic hose

### Optional Accessories

- Foot operated control with guard
- Approach ramp
- Pallet truck approach ramp



Full Perimeter Electric Toeguard



2.9" Lowered Height On Models Up To 1,100lbs



Remote Power Unit



Bishamon Industries Corporation

5651 East Francis Street  
Ontario, California 91761-3601  
(909) 390-0055 • (800) 358-8833  
Fax (909) 390-0060

DISTRIBUTED BY:

[www.bishamon.com](http://www.bishamon.com)